



UNIVERSAL/MULTIFLEX

INTERNATIONAL

Factory Parts Catalog

Product No.	MED10ZEMW0
Market	Export
Color	white
Wiring Diagram	137406200
Owner's Guide	137529700

INTERNATIONAL

P.O. BOX 8020
CHARLOTTE, NC 28262

ELECTRIC DRYER

Model No.
MED10ZEM

Publication No.
5995634986
13/07/24
(EN/SERVICE/SLS)
154

CABINET/DRUM

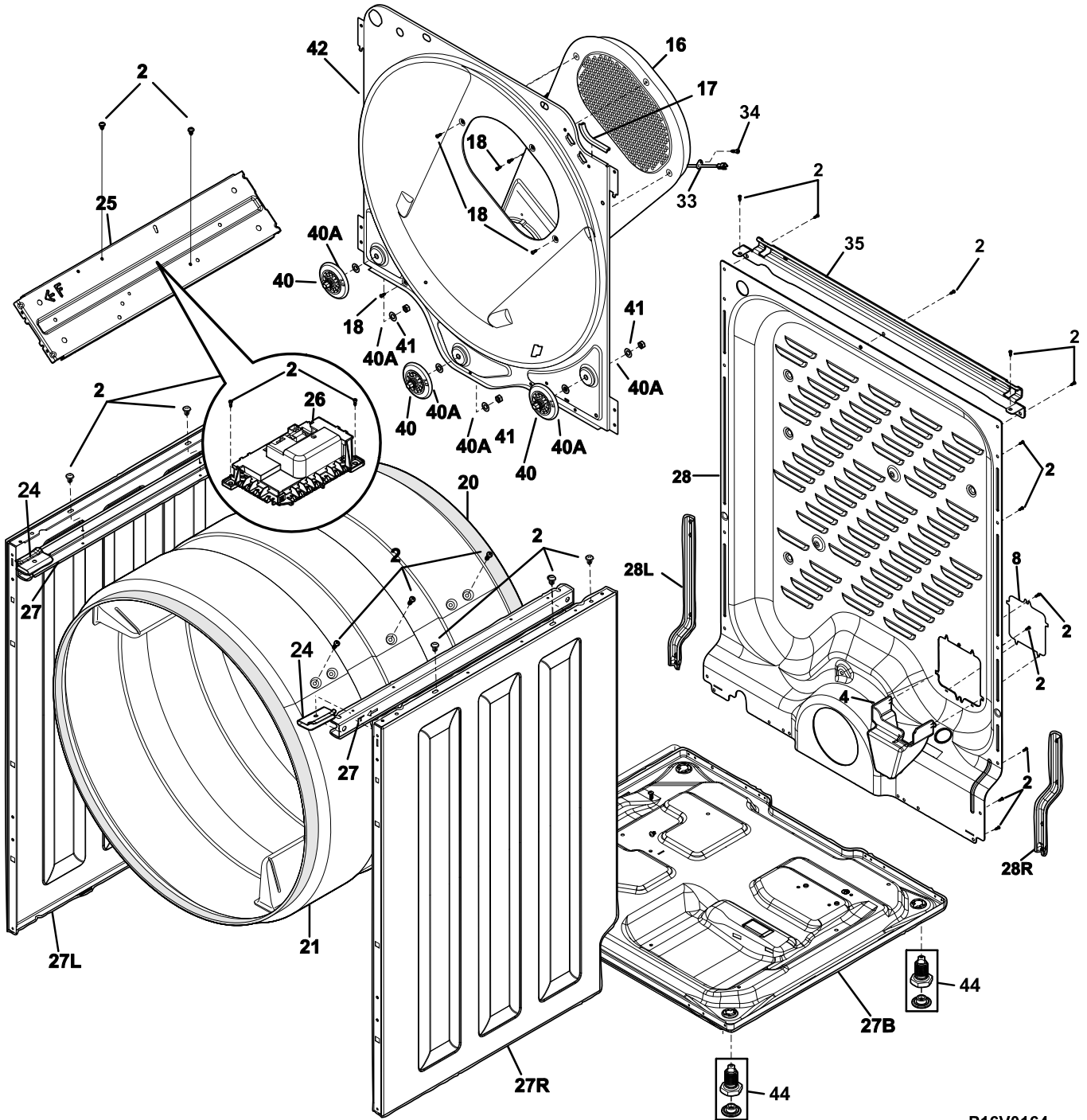
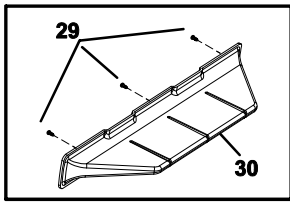

P16V0164

CABINET/DRUM

POS. NO	PART NO.	DESCRIPTION
2	131168200	Screw, pan head, 8-18B x 0.31
4	134792200	Bracket, mounting, terminal block
8	137150100	Cover, terminal block, without gasket
8*	137212300	Gasket, terminal cover
16	134694030	Duct, heat, rear
17	134792900	Protector, edge, right top front, 85.0+/-1.5
18	131477000	Screw, 10-16AB x 0.375
20	137565300	Seal, felt, drum
20*	5308027429	Adhesive, high temp
21	134711900	Drum, dryer, assembly 36"
24	137301700	Bracket, front, top supp
25	134912100	Bracket, mounting, main control bx
26 #	137454505	Control Board, pc w/housing
27	137240400	Brace, side panel, left or right
27*	137360810	Protector, Edge, side brace
27B	134690201	Base, dryer, washed
27L	134690310	Panel, left side, white
27R	134690410	Panel, right side, white
28	137506600	Panel, backsheet, rear
28L	137029900	Bracket, reinforcement, left, backsheet
28R	137066800	Bracket, reinforcement, right, backsheet
29	131205100	Screw, #8 pan head, 10-10B x 0.500, cr/sq drive
30	137623200	Vane, drum
33 #	3204267	Thermostat, safety
34	131243700	Screw, pan head, 8-18AB x 0.375
35	137274600	Bracket, rear, tp, FSD
40	134715900	Roller, wheel, complete asmy
40*	134716200	Retainer, roller wheel, assembly
40A	134716700	Washer, flat
41	134716800	Nut, 3/8-16
42	134712816	Bulkhead, painted, rear
42*	134154100	Screw, hex washer head, 10-32 x 0.375, ground
44	137029700	Leveling Leg, screw

FRONT PANEL/LINT FILTER

POS. NO	PART NO.	DESCRIPTION
1	137068200	Seal, air duct
6	134710705	Duct, air, gray
8	134701310	Cover, lint housing
9	131633200	Plug, white
18	134430300	Screw, indt pan head, 10-14 x 0.625, quadrex
20	137116600	Gasket, front panel
20*	5308027429	• Adhesive, high temp
22	137365911	Panel, front, FSD
24 #	137546100	Harness, door switch
25	131658800	Door Catch, upper
26 #	5304475549	Switch, door
27	134701410	Filter, lint, complete
28	137034500	Clip, mounting, cabinet front
34A	137285100	Screw, pan head, #8-18x.750
38	137361500	Screw 8-18X0.711 Combo
39	137365610	Hinge, piano style
40	134715900	Roller, wheel, complete asmy
40*	134716200	Retainer, roller wheel, assembly
40A	134716700	Washer, flat
41	134716800	Nut, 3/8-16
42	134696110	Bulkhead, panel, front
47	137554211	Door, inner, FSD, white
48	137026510	Door, outer, FSD, white
48*	137138602	Door Strike
53	137274200	Handle, door, FSD
55	137365800	Spacer, FSD door
58	137576600	Plug, light hole
70	134417500	Plug, rectangular, white

CONTROLS/TOP PANEL

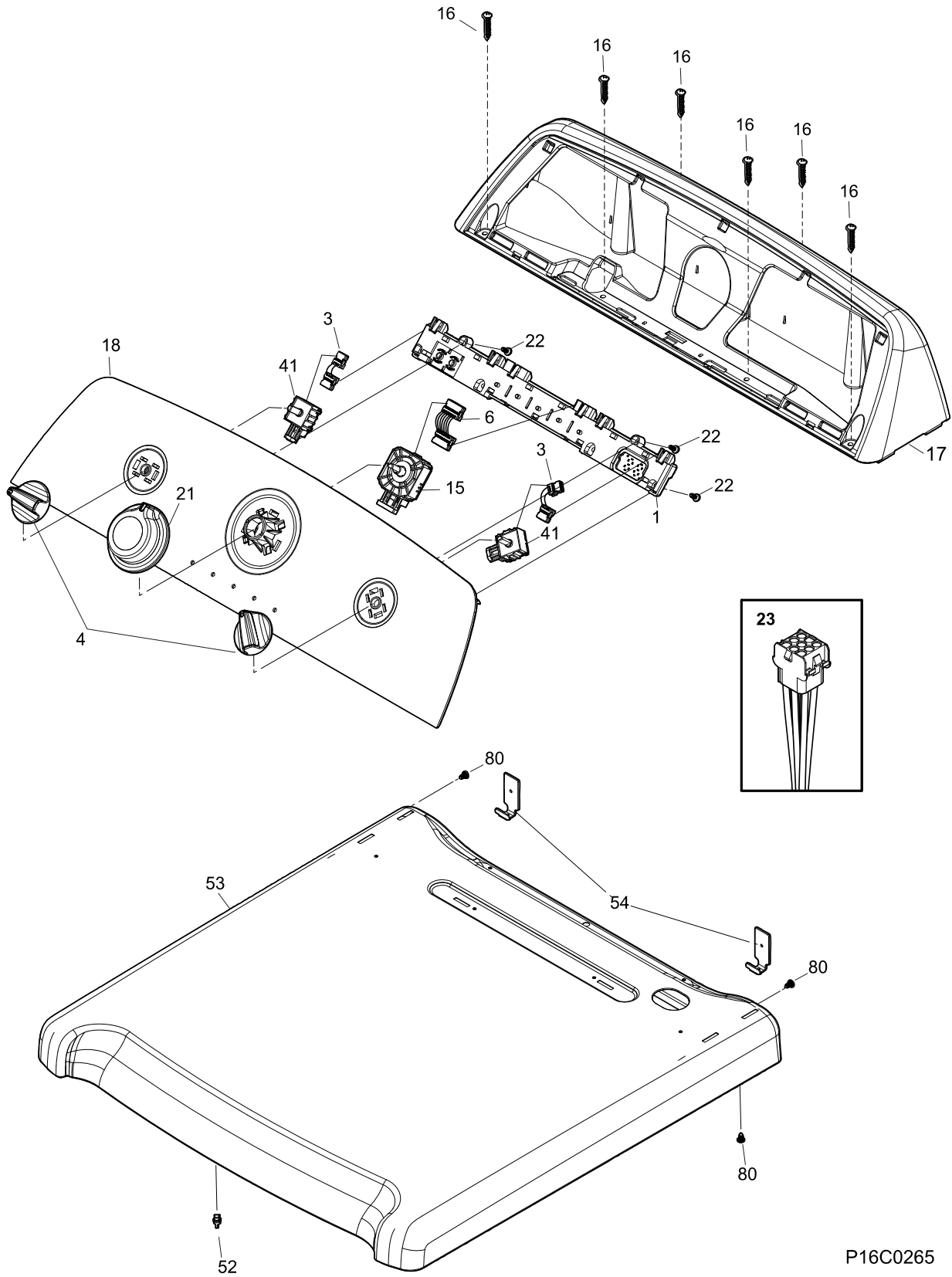

P16C0265

CONTROLS/TOP PANEL

POS. NO	PART NO.	DESCRIPTION
1 #	137332400	Control Board, pc w/housing
3	137155700	Harness Upper-1, option switch
4	137053300	Knob, switch
6	137348800	Harness, upper prog sel
15 #	137493300	Switch, PTS cycle, 8 position
16	3205239	Screw-hinge, splnd ab st/c, 10.16 x 0.50
17	137054110	Console, shell J, white
18	137434500	Panel, dec control
21	137489600	Knob, cycle selector
22	3205253	Screw, pan head, 6-20B X 0.375
23 #	137546200	Harness, main, elect
41 #	137261000	Switch, rotary, 4 pos
52	137362600	Pin, panel locator
53	137274810	Panel, top panel, white
54	137329700	Bracket, hinge, rear
80	131168200	Screw, pan head, 8-18B x 0.31

MOTOR

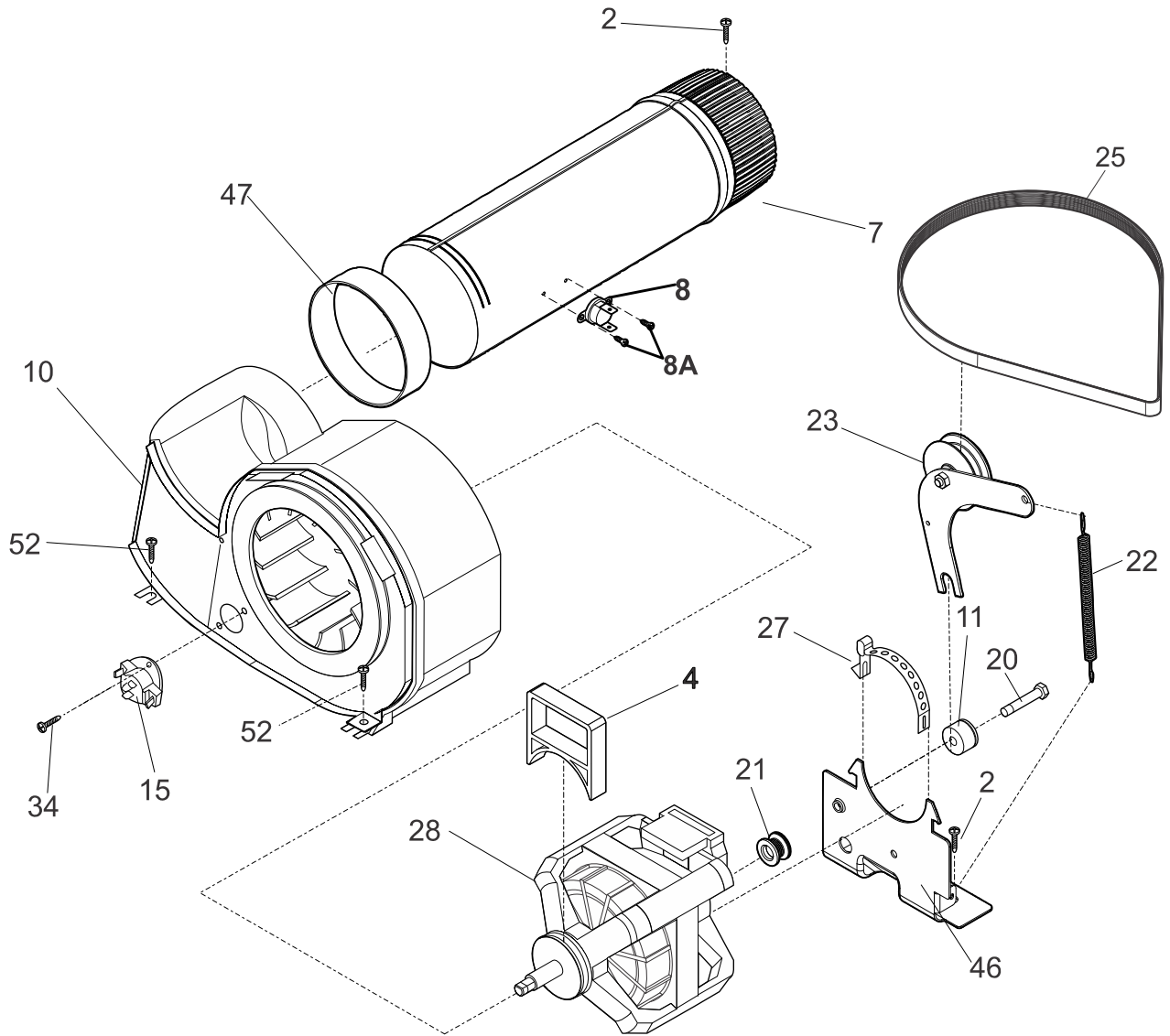

P16M0041

MOTOR

POS. NO	PART NO.	DESCRIPTION
2	131168200	Screw, pan head, 8-18B x 0.31
4	131435200	Lock, blower housing
7	134693900	Tube, exhaust, rear
8 #	137515200	Limiter, thermal exhaust, flush mount
8A	134935200	Screw, #6 pan head, #8-32 X .25, quadrex
10 #	131775610	Blower Assy, housing, w/cover & wheel
11	131749800	Spacer, idler
15 #	134587700	Thermistor, control
20	131017900	Bolt, hex head, 1/4-20T x 1.25, thread cutting
21 #	134828600	Pulley, motor, back shaft, 50/60 Hz cvrsn
22	131601000	Spring, idler arm
23	134793500	Idler Arm Assy, w/pulley
25 #	134719300	Belt, "H", poly V, 5 rib
27	134242400	Clamp, motor mtg.
28 #	137061300	Motor, 220-240 50/60hz, with out pulley
34	131243700	Screw, pan head, 8-18AB x 0.375
46	134693500	Bracket, motor mounting
47	131633300	Seal, exhaust tube
52	131202300	Screw, 10-16AB x 0.625

BURNER

POS. NO	PART NO.	DESCRIPTION
1 #	137406400	Heater, 1 element, 4300
2	131168200	Screw, pan head, 8-18B x 0.31
3	134692700	Shield, radiant, electric
4	134785000	Bracket, heater/burner, mounting
8	137211800	Limiter, thermal, heater
8A	134935200	Screw, #6 pan head, #8-32 X .25, quadrex
33 #	137511700	Thermostat, high limit intl

WIRING DIAGRAM

